



## The integer-antimagic spectra of Hamiltonian graphs

Ugur Odabasi<sup>a</sup>, Dan Roberts<sup>b</sup>, Richard M. Low<sup>c</sup>

<sup>a</sup>Department of Engineering Sciences, Istanbul University-Cerrahpasa, Istanbul, 34320, Turkey

<sup>b</sup>Department of Mathematics, Illinois Wesleyan University, Bloomington, IL, 61701, USA

<sup>c</sup>Department of Mathematics and Statistics, San Jose State University, San Jose, CA, 95192, USA

ugur.odabasi@istanbul.edu.tr, drobert1@iwu.edu, richard.low@sjsu.edu

### Abstract

Let  $A$  be a nontrivial abelian group. A connected simple graph  $G = (V, E)$  is  $A$ -antimagic, if there exists an edge labeling  $f : E(G) \rightarrow A \setminus \{0_A\}$  such that the induced vertex labeling  $f^+(v) = \sum_{\{u,v\} \in E(G)} f(\{u, v\})$  is a one-to-one map. The *integer-antimagic spectrum* of a graph  $G$  is the set  $\text{IAM}(G) = \{k : G \text{ is } \mathbb{Z}_k\text{-antimagic and } k \geq 2\}$ . In this paper, we determine the integer-antimagic spectra for all Hamiltonian graphs.

*Keywords:* Hamiltonian graphs, graph labeling, group-antimagic labeling

Mathematics Subject Classification : 05C15

DOI: 10.5614/ejgta.2021.9.2.5

### 1. Introduction

A labeling of a graph is defined to be an assignment of values to the vertices and/or edges of the graph. Graph labeling is a very diverse and active field of study. A dynamic survey [2] maintained by Gallian contains 2922 references to research papers and books on the topic.

Let  $G$  be a connected simple graph. For any nontrivial abelian group  $A$  (written additively), let  $A^* = A \setminus \{0_A\}$ , where  $0_A$  is the additive identity of  $A$ . Let function  $f : E(G) \rightarrow A^*$  be an edge labeling of  $G$ . Any such labeling induces a vertex labeling  $f^+ : V(G) \rightarrow A$ , defined by  $f^+(v) = \sum_{\{u,v\} \in E(G)} f(\{u, v\})$ . We denote the range of  $f^+$  by  $\mathcal{R}_f(G)$ . If there exists an

Received: 19 May 2020, Revised: 13 February 2021, Accepted: 19 March 2021.

edge labeling  $f$  whose induced map  $f^+$  on  $V(G)$  is one-to-one, we say that  $f$  is an  $A$ -antimagic labeling and that  $G$  is an  $A$ -antimagic graph. The integer-antimagic spectrum of a graph  $G$  is the set  $\text{IAM}(G) = \{k : G \text{ is } \mathbb{Z}_k\text{-antimagic and } k \geq 2\}$ .

The concept of the  $A$ -antimagicness property for a graph  $G$  (introduced independently in [1, 3]) naturally arises as a variation of the  $A$ -magic labeling problem (where the induced vertex labeling is a constant map). There is a large body of research on  $A$ -magic graphs within the mathematical literature. As for  $A$ -antimagic graphs (which is the focus of our paper), cycles, paths, various classes of trees, dumbbells, graphs with a chord, multi-cyclic graphs,  $K_{m,n}$ ,  $K_{m,n} - \{e\}$ , tadpoles and lollipop graphs were investigated in [1, 3, 4, 5, 7, 8, 9].

First, we include some known results which will be used in the rest of the paper. In particular, the results from the theorems in this section are used in the constructions of new  $\mathbb{Z}_k$ -antimagic labelings in this paper.

A trivial lower bound for the least element of  $\text{IAM}(G)$  is the order of  $G$ . However, this is not always achieved, as seen in the following result.

**Lemma 1.1** ([1]). *For all  $m \in \mathbb{Z}^+$ , a graph of order  $4m + 2$  is not  $\mathbb{Z}_{4m+2}$ -antimagic.*

Motivation for our current work is found in the following conjecture.

**Conjecture 1** ([5]). *Let  $G$  be a connected simple graph. If  $t$  is the least positive integer such that  $G$  is  $\mathbb{Z}_t$ -antimagic, then  $\text{IAM}(G) = \{k : k \geq t\}$ .*

A result of Jones and Zhang [3] finds the minimum element of  $\text{IAM}(G)$  for all connected graphs on 3 or more vertices. In their paper, a  $\mathbb{Z}_n$ -antimagic labeling of a graph on  $n$  vertices is referred to as a nowhere-zero modular edge-graceful labeling. This is a variation of a graceful labeling (originally called a  $\beta$ -valuation) which was introduced by Rosa [6] in 1967. The result is as follows, where the terminology has been adapted to better suit this paper.

**Theorem 1.1** ([3]). *If  $G$  is a connected simple graph of order  $n \geq 3$ , then  $\min\{t : t \in \text{IAM}(G)\} \in \{n, n + 1, n + 2\}$ . Furthermore,*

- $\min\{t : t \in \text{IAM}(G)\} = n$  if and only if  $n \not\equiv 2 \pmod{4}$ ,  $G \neq K_3$ , and  $G$  is not a star of even order;
- $\min\{t : t \in \text{IAM}(G)\} = n + 1$  if and only if  $G = K_3$  or  $n \equiv 2 \pmod{4}$  and  $G$  is not a star of even order; and
- $\min\{t : t \in \text{IAM}(G)\} = n + 2$  if and only if  $G$  is a star of even order.

Conjecture 1 was shown to be true for all of the classes of graphs which were analyzed in [1, 4, 5, 7, 8, 9]. The purpose of this paper is to provide additional evidence for Conjecture 1 by verifying it for a large family of graphs including all Hamiltonian graphs. We use constructive methods to determine the integer-antimagic spectra of the graph classes in question.

If  $a$  and  $b$  are integers with  $a \leq b$ , let  $[a, b]$  denote the set  $\{a, a + 1, \dots, b\}$ . Let  $(v_0, v_1, \dots, v_{m-1})$  denote the  $m$ -cycle with edges  $\{v_i, v_{i+1}\}$ , for  $i \in [0, m - 2]$  and  $\{v_0, v_{m-1}\}$ . Consider the cycle  $C_m = (v_0, v_1, \dots, v_{m-1})$ . Define the  $x$ -alternating cycle labeling of  $C_m$ , starting with the edge

$\{v_i, v_{i+1}\}$ , to be the function  $g_x : E(C_m) \rightarrow \{x, -x\}$  such that  $g_x(\{v_i, v_{i+1}\}) = x$  and  $g_x$  alternates between  $-x$  and  $x$ , where  $x \in A$  for some additive group  $A$ .

We will make use of the following result in our main construction.

**Theorem 1.2** ([1]). *If  $m \equiv 0, 1, 3 \pmod{4}$ , then  $\text{IAM}(C_m) = \{k : k \geq m\}$ . If  $m \equiv 2 \pmod{4}$ , then  $\text{IAM}(C_m) = \{k : k \geq m + 1\}$ .*

## 2. Graphs with an even cycle

The following technical lemma is important and will be used throughout this paper.

**Lemma 2.1.** *Let  $f$  be a  $\mathbb{Z}_k$ -antimagic labeling of a graph  $G$  and let  $G' = G \cup \{\{u, v\}\}$ , where  $u, v \in V(G)$  and  $\{u, v\} \notin E(G)$ . Suppose  $\{u, v\}$  lies on a non-Hamiltonian even cycle  $C_m$  in  $G'$ . Then, there is a  $\mathbb{Z}_k$ -antimagic labeling  $h$  of  $G'$  such that  $\mathcal{R}_f(G) = \mathcal{R}_h(G')$ .*

*Proof.* Let  $f : E(G) \rightarrow \mathbb{Z}_k \setminus \{0\}$  be a  $\mathbb{Z}_k$ -antimagic labeling of  $G$  and  $C_m = (v_0, v_1, \dots, v_{m-1})$  be an even cycle in  $G'$ , where  $u = v_0$  and  $v = v_{m-1}$ . Since  $m \leq |V(G)| - 1$  and  $|V(G)| \leq k$ , we have  $m - 1 \leq k - 2$  if  $k$  is odd, and  $m - 1 \leq k - 3$  if  $k$  is even. Thus by the Pigeonhole Principle, we may assume that there exists  $x \in \mathbb{Z}_k \setminus \{0\}$  with the following properties: (i)  $x \neq -x$ , (ii) at most one of the edges  $\{v_i, v_{i+1}\}$  (where  $0 \leq i \leq m - 2$ ) is labeled with  $x$ , and (iii) none of the edges  $\{v_i, v_{i+1}\}$  (where  $0 \leq i \leq m - 2$ ) are labeled with  $-x$ . Otherwise, the multiset  $\cup_{i=1}^{m-1} \{f(\{v_{i-1}, v_i\})\}$  would contain every integer  $x$  in  $\{1, 2, \dots, k - 1\}$  and its additive inverse at least once. In this case, we would have  $k - 1 \leq m - 1$ . We define  $h : E(G') \rightarrow \mathbb{Z}_k \setminus \{0\}$  by

$$h(e) = f(e) + w(e),$$

where addition is in  $\mathbb{Z}_k$  and

$$w(e) = \begin{cases} g_x(e), & \text{if } e \in E(C_m), \\ 0, & \text{otherwise.} \end{cases}$$

Here,  $g_x$  is the  $x$ -alternating cycle labeling of the cycle  $C_m$  starting with the only edge  $e^*$ , for which  $f(e^*) = x$ ; otherwise, if  $f(e) \neq x$  for all  $e \in E(C_m) \setminus \{u, v\}$ , then  $g_x$  can start at any edge in the cycle. Clearly,  $w^+(v) = 0$  for all  $v \in V(G)$  so  $h^+(v) = f^+(v)$ . Moreover, all the edges of  $C_m$  are labeled with a non-zero integer in  $\mathbb{Z}_k$  since  $f(\{v_i, v_{i+1}\})$  does not take value  $-x$  for  $i \in [0, m - 2]$ . Thus,  $h$  is the desired  $\mathbb{Z}_k$ -antimagic labeling of  $G'$ .  $\square$

*Example 1.* This example demonstrates how the overlaying of an alternating cycle labeling works (see  $f$ ,  $h$ , and  $x$  found in the proof of Lemma 2.1). Let  $f : E(C_{12}) \rightarrow \mathbb{Z}_k \setminus \{0\}$  be a  $\mathbb{Z}_k$ -antimagic labeling of  $C_{12}$  as shown in Figure 1(a), and  $h : E(C_{12}) \rightarrow \mathbb{Z}_k \setminus \{0\}$  be the labeling of  $C_{12}$  defined by  $h(e) = f(e) + g(e)$  as shown in Figure 1(b) where  $g$  is the  $x$ -alternating cycle labeling of the cycle  $C_{12}$ . It is clear that, for  $x \in \{1, 3, 8, 10\}$ ,  $h$  is also a  $\mathbb{Z}_k$ -antimagic labeling of  $C_{12}$ , for  $k \geq 12$ .

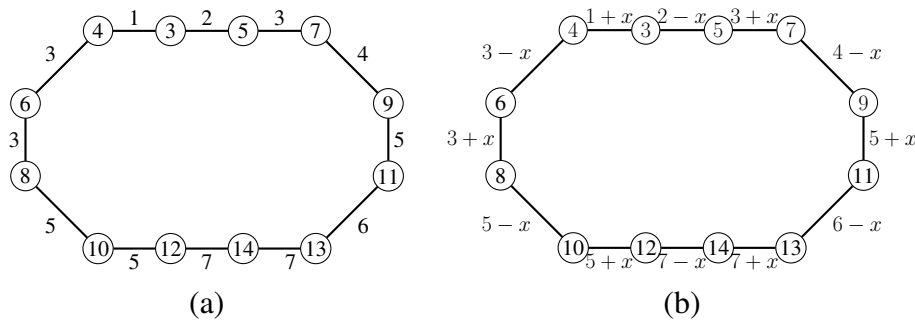

Figure 1. Two different  $\mathbb{Z}_k$ -antimagic labelings of  $C_{12}$ , for  $k \geq 12$ .

### 3. Chorded cycles

Let  $C_m$  be the cycle  $(v_0, v_1, \dots, v_{m-1})$ . A *chord* of  $C_m$  is an edge not in  $E(C_m)$  whose endpoints lie in the vertex set  $V(C_m)$ . If  $C_m$  has at least one chord, then it is called a *chorded cycle*. We define  $C_m(l)$  to be the graph obtained from  $C_m$  by adding the chord  $\{v_i, v_j\}$ , where  $l = \min\{|i - j|, m - |i - j|\}$  which is called the *length* of the chord. Note that the length of any chord in a cycle  $C_m$  is at least 2 and at most  $\lfloor \frac{m}{2} \rfloor$ .

An  $m$ -cycle with a chord of length  $l$  is denoted by  $C_m(l)$ . Note that  $C_m(l)$  is the union of two cycles which share exactly one edge – the chord. We call the shorter of the two cycles the *minor subcycle* of  $C_m(l)$ , denoted by  $C_m^-(l)$ , and the longer of the two cycles the *major subcycle* of  $C_m(l)$ , denoted by  $C_m^+(l)$ .

In [4], the integer-antimagic spectrum for cycles with a chord was determined completely.

**Theorem 3.1** ([4]). *Let  $m$  be an integer and let  $l \in [2, \lfloor \frac{m}{2} \rfloor]$  be an integer. Then,  $\text{IAM}(C_m(l)) = \{k : k \geq m\}$  if  $m \equiv 0, 1, 3 \pmod{4}$  and  $\text{IAM}(C_m(l)) = \{k : k \geq m + 1\}$  if  $m \equiv 2 \pmod{4}$ .*

In Lemma 2.1, it was shown that  $\mathbb{Z}_k$ -antimagicness can be preserved when an edge is added, provided that edge lies on an even cycle. However, if the added edge lies on only odd cycles, we will make use of Lemmas 3.1 and 3.2. Also by Lemma 3.1, we can obtain an integer-antimagic labeling of a cycle with more than one chord and we will use this result in our main construction.

We will need the following technical lemma for the proof of Lemma 3.2.

**Lemma 3.1.** *Let  $m, l_1$ , and  $l_2$  be even with  $l_1, l_2 \in [2, \frac{m}{2}]$ . Let  $f$  be a  $\mathbb{Z}_k$ -antimagic labeling of the cycle  $C_m$  and let  $C'_m = C_m \cup \{c_1, c_2\}$ , where  $c_1$  and  $c_2$  are two different chords of lengths  $l_1$  and  $l_2$ , respectively, in  $C_m$ . Then, there is a  $\mathbb{Z}_k$ -antimagic labeling  $h$  of  $C'_m$  such that  $\mathcal{R}_f(C_m) = \mathcal{R}_h(C'_m)$ .*

*Proof.* Let  $f : E(C_m) \rightarrow \mathbb{Z}_k \setminus \{0\}$  be a  $\mathbb{Z}_k$ -antimagic labeling of  $C_m = (v_0, v_1, \dots, v_{m-1})$ . Without loss of generality, assume  $c_1$  and  $c_2$  are chords of lengths  $l_1$  and  $l_2$  in  $C_m$  with end points  $\{v_0, v_{l_1}\}$  and  $\{v_s, v_t\}$ , respectively. Also, we may assume  $s < t$  where  $s, t \in \mathbb{Z}_m$ . It is easy to check that  $l_2 = \min\{t - s, m - t + s\}$  and since  $l_2$  is even,  $s$  and  $t$  have the same parity. Here, we separate the problem into four cases.

**Case 1.** First, assume  $s = 0$ . We define the cycle  $C = (u_0, u_1, \dots, u_{|l_1-t|+1})$  in  $C'_m$ , where  $u_0 = v_0$  and  $u_i = v_{t+\text{sgn}(l_1-t)(i-1)}$ , for  $i \in [1, \text{sgn}(l_1 - t)(l_1 - t) + 1]$ . Here,  $\text{sgn}(\cdot)$  denotes

the signum function. It is obvious that  $C$  contains both  $c_1 = \{v_0, v_{l_1}\}$  and  $c_2 = \{v_0, v_t\}$  and  $|V(C)| = |l_1 - t| + 2$ ; that is,  $C$  is an even cycle in  $C'_m$  satisfying  $|V(C)| < m - 1$ .

**Case 2.** Let  $0 < s < l_1$  and define the cycle  $C = (u_0, u_1, \dots, u_{|l_1-t|+s+1})$ , where  $u_i = v_i$  for  $i \in [0, s]$  and  $u_{s+i} = v_{t+sgn(l_1-t)(i-1)}$  for  $i \in [1, |l_1 - t| + 1]$ . Here, if  $s = l_1 - 1$  and  $t = m - 1$ , then  $C$  will be a cycle of length  $m$ . In this case, we will take the  $C$  as the 4-cycle  $(v_0, v_t, v_s, v_{l_1})$ . It is easy to check that  $C$  contains both  $c_1 = \{v_0, v_{l_1}\}$  and  $c_2 = \{v_s, v_t\}$  and  $|V(C)| = |l_1 - t| + s + 2$ ; that is,  $C$  is an even cycle in  $C'_m$  satisfying  $|V(C)| < m - 1$ .

**Case 3.** Assume  $s = l_1$  and define the cycle  $C = (u_0, u_1, \dots, u_{m-t+1})$ , where  $u_{m-t+1} = v_{l_1}$  and  $v_i = v_{-i}$  for  $i \in [0, m - t]$ . Then,  $C$  contains both  $c_1 = \{v_0, v_{l_1}\}$  and  $c_2 = \{v_s, v_t\}$  and  $|V(C)| = m - t + 2$ ; that is,  $C$  is an even cycle in  $C'_m$  satisfying  $|V(C)| < m - 1$ .

**Case 4.** Assume  $l_1 < s \leq m - 1$  and define the cycle  $C = (u_0, u_1, \dots, u_{m-t+s-l_1+1})$ , where  $u_i = v_{-i}$  for  $i \in [0, m - t]$  and  $u_{m-t+i} = v_{s-i-1}$  for  $i \in [1, s - l_1 + 1]$ . It can be checked that  $C$  contains both  $c_1 = \{v_0, v_{l_1}\}$  and  $c_2 = \{v_s, v_t\}$  and  $|V(C)| = m - t + s - l_1 + 2$ ; that is,  $C$  is an even cycle in  $C'_m$  satisfying  $|V(C)| < m - 1$ .

In all cases, we are able to find an even cycle  $C$  in  $C'_m$  containing both edges  $c_1$  and  $c_2$  which satisfies  $|V(C)| < m - 1$ . Since  $m \leq k$  and  $|V(C)| < m - 1$ , we have  $|V(C)| < k - 1$ . Thus by the Pigeonhole Principle, we may assume that there exists  $x \in \mathbb{Z}_k \setminus \{0\}$  for which  $x \neq -x$  such that at most one of the edges of  $C \setminus \{c_1, c_2\}$  is labeled with  $x$  while none of which is labeled with  $-x$ . Otherwise, the multiset  $\{f(E(C) \setminus \{c_1, c_2\})\}$  would contain every integer  $x$  in  $\{1, 2, \dots, k - 1\}$  and its additive inverse at least once, hence, we would have  $k - 1 \leq |V(C)| - 2$ . We define  $h : E(C'_m) \rightarrow \mathbb{Z}_k \setminus \{0\}$  by

$$h(e) = f(e) + w(e),$$

where addition is in  $\mathbb{Z}_k$  and

$$w(e) = \begin{cases} g_x(e), & \text{if } e \in E(C), \\ 0, & \text{otherwise.} \end{cases}$$

Here,  $g_x$  is the  $x$ -alternating cycle labeling of the cycle  $C$  starting with the only edge  $e^*$ , for which  $f(e^*) = x$ ; otherwise, if  $f(e) \neq x$  for all  $e \in E(C)$ , then  $g_x$  can start at any edge in the cycle. Clearly,  $w^+(v) = 0$  for all  $v \in V(C_m)$ , so  $h^+(v) = f^+(v)$ . Moreover, all the edges of  $C$  are labeled with a non-zero integer in  $\mathbb{Z}_k$  since  $f(e)$  does not take value  $-x$ , for all  $e \in E(C)$ . Thus,  $h$  is the desired  $\mathbb{Z}_k$ -antimagic labeling of  $C'_m$ .  $\square$

**Lemma 3.2.** Let  $m$  be an integer and let  $l_1, l_2 \in [2, \lfloor \frac{m}{2} \rfloor]$ , where  $l_1$  and  $l_2$  have the same parity when  $m$  is even. Also let  $f$  be a  $\mathbb{Z}_k$ -antimagic labeling of a graph  $G$  and let  $G' = G \cup \{c_1, c_2\}$ . If the edges  $c_1$  and  $c_2$  are two different chords of lengths  $l_1$  and  $l_2$ , respectively, of a cycle  $C_m$  in  $G'$ , then there is a  $\mathbb{Z}_k$ -antimagic labeling  $h$  of  $G'$  such that  $\mathcal{R}_f(G) = \mathcal{R}_h(G')$ .

*Proof.* Let  $f : E(G) \rightarrow \mathbb{Z}_k \setminus \{0\}$  be a  $\mathbb{Z}_k$ -antimagic labeling of  $G$ . If the length  $l_i$  of a chord  $c_i$  in  $C_m$  is odd, then the minor subcycle  $C_m^-(l_i)$  is an even cycle in  $G'$  with  $|V(C_m^-(l_i))| < |V(G)| - 1$ . So applying Lemma 2.1 gives the result for odd length chords  $l_1$  and  $l_2$ . Similarly, if  $m$  is odd, then

$|V(C_m^+(l_i))|$  and  $|V(C_m^-(l_i))|$  have different parities; that is, there exists at least one even cycle in  $G'$  which includes the chord  $c_i$  for  $i = 1, 2$ . Thus by Lemma 2.1, we have the desired labeling of  $G'$ .

Let  $m, l_1$ , and  $l_2$  be even and let  $c_1$  and  $c_2$  be two different chords of  $C_m$ . We can apply Lemma 3.1 to the restriction of  $f$  to  $C_m$  to obtain a  $\mathbb{Z}_k$ -antimagic labeling of  $C'_m = C_m \cup \{c_1, c_2\}$  that preserves the vertex labels of  $f$ . Combining this new labeling with the original  $f$  labeling on the edges in  $G \setminus E(C_m)$  gives us the desired  $\mathbb{Z}_k$ -antimagic labeling of  $G'$ .  $\square$

*Example 2.* In Figure 2(a), the 14-cycle  $C_{14} = (v_0, v_1, v_2, \dots, v_{13})$  and a  $\mathbb{Z}_k$ -antimagic labeling of it is shown, for  $k \geq 15$ . Figures (b), (c), and (d) show three possible cases for adding two chords to  $C_{14}$ . The overlaid  $x$ -alternating cycles were each constructed via the method described in the proof of Lemma 3.1.

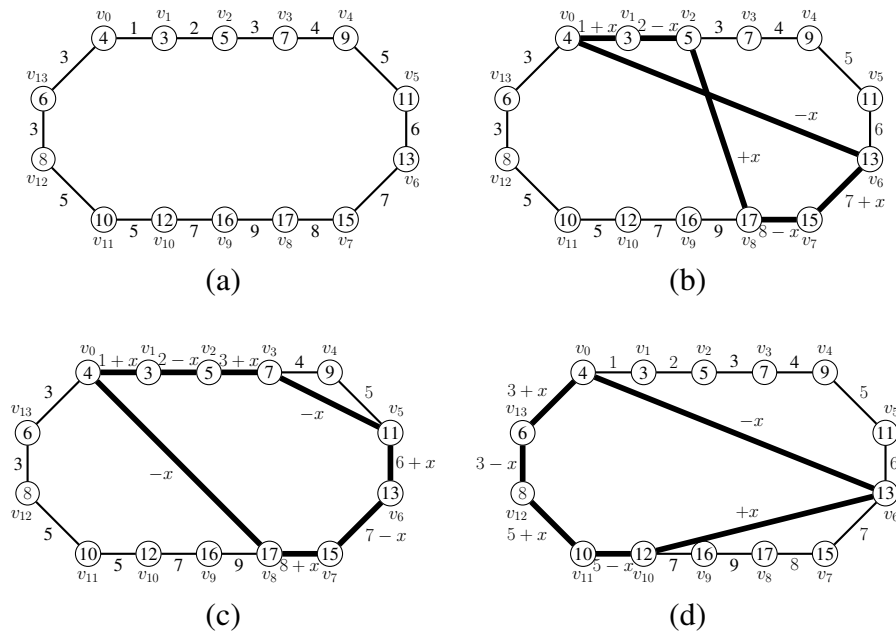

Figure 2. Figures (b), (c), and (d) show possible overlaying processes which maintain the  $\mathbb{Z}_k$ -antimagic property of  $C_{14}$ , for  $k \geq 15$ .

#### 4. Hamiltonian graphs of odd order

A *Hamiltonian cycle* in a graph  $G$  is a cycle that contains all vertices of  $G$ , and a graph is said to be *Hamiltonian* if it contains a Hamiltonian cycle. In this section, we determine the integer-antimagic spectra for all Hamiltonian graphs of odd order.

**Theorem 4.1.** *Every Hamiltonian graph  $G$  of odd order is  $\mathbb{Z}_k$ -antimagic, for  $k \geq |V(G)|$  and  $G \neq K_3$ .*

*Proof.* Let  $m$  be a positive odd integer and  $G$  be a graph of order  $m$  possessing the cycle  $C_m = (v_0, v_1, \dots, v_{m-1})$ . By Theorem 1.2,  $C_m$  is  $\mathbb{Z}_k$ -antimagic for  $k \geq m$ .

When two vertices  $v_i$  and  $v_j$  ( $i \neq j$ ) of the cycle  $C_m$  are joined by a chord, the resulting graph, say  $C_m^*$ , is always the union of an even cycle and an odd cycle which share one edge  $\{v_i, v_j\}$ . Thus by Lemma 2.1,  $C_m^*$  is  $\mathbb{Z}_k$ -antimagic for  $k \geq m$ , since the edge  $\{v_i, v_j\}$  lies on an even cycle in  $C_m^*$ . Whenever an edge is added to the new resulting graph, the added edge belongs to an even cycle. Applying the same construction as in Lemma 2.1 gives a  $\mathbb{Z}_k$ -antimagic graph for  $k \geq m$ .  $\square$

### 5. Hamiltonian graphs of even order

In this section, we determine the integer-antimagic spectra of the Hamiltonian graphs of even order. When we add an even-length chord to an even cycle, both the minor and major subcycles have odd lengths. By applying Theorem 3.1 and Lemma 3.2, we will be able to obtain the desired labelings of Hamiltonian graphs of even order.

**Theorem 5.1.** *Let  $G$  be a Hamiltonian graph. If  $|V(G)| \equiv 0 \pmod{4}$ , then  $G$  is  $\mathbb{Z}_k$ -antimagic, for  $k \geq |V(G)|$ . If  $|V(G)| \equiv 2 \pmod{4}$ , then  $G$  is  $\mathbb{Z}_k$ -antimagic, for  $k \geq |V(G)| + 1$ .*

*Proof.* Let  $C_m = (v_0, v_1, \dots, v_{m-1})$  be a Hamiltonian cycle in graph  $G$  and let  $C(G)$  be the subset of  $E(G)$  defined as  $C(G) = E(G) \setminus E(C_m)$ . We can think of each element of  $C(G)$  as a chord of  $C_m$ . We will construct  $G$  by adding chords to the Hamiltonian cycle  $C_m$ . If the length of a chord is odd, then the corresponding minor subcycle is an even cycle. Thus by Lemma 2.1, regardless how many odd length chords are added to  $C_m$ , the resulting graph is always  $\mathbb{Z}_k$ -antimagic. Similarly, if the number of even length chords is even, then we can pair up these even length chords and add them to  $C_m$  as pairs. Thus by Lemma 3.2, this edge addition does not change the group-antimagicness. Lastly, if the number of even length chords is odd, then we first add a single odd length chord to  $C_m$ , and denote as  $C_m^*$ . By Theorem 3.1,  $C_m^*$  is a  $\mathbb{Z}_k$ -antimagic graph as well. Again, we can pair up the remaining even length chords and keep adding to  $C_m^*$  as pairs until we have  $G$  as the resulting graph. By Lemma 3.2, adding a pair of even length chords to a  $\mathbb{Z}_k$ -antimagic graph preserves the group-antimagicness.  $\square$

### 6. Conclusion

Combining the results of Theorems 4.1 and 5.1, we obtain the following main result of this paper.

**Theorem 6.1.** *Suppose  $G$  is a Hamiltonian graph of order  $n$ . Then,*

$$\text{IAM}(G) = \begin{cases} [4, \infty), & \text{if } G = K_3, \\ [n, \infty), & \text{if } n \equiv 0, 1, 3 \pmod{4} \text{ and } G \neq K_3, \\ [n + 1, \infty), & n \equiv 2 \pmod{4}. \end{cases}$$

In addition to Hamiltonian graphs, note that our results in Lemmas 2.1, 3.1, and 3.2 are valid for graphs that contain at least one even cycle as well. These lemmas can be used in analyzing the integer-antimagic spectra of other classes of graphs.

## Acknowledgment

The authors are grateful to the anonymous referee, whose valuable comments and suggestions improved the final manuscript.

## References

- [1] W.H. Chan, R.M. Low, and W.C. Shiu, Group-antimagic labelings of graphs, *Congr. Numer.*, **217** (2013), 21–31.
- [2] J.A. Gallian, A dynamic survey of graph labeling, *Electron. J. Combin.*, Dynamic Survey DS6, (2020), <http://www.combinatorics.org>.
- [3] R. Jones and P. Zhang, Nowhere-zero modular edge-graceful graphs, *Discuss. Math. Graph Theory*, **32** (2012), 487–505.
- [4] R.M. Low, D. Roberts, and J. Zheng, The integer-antimagic spectra of graphs with a chord, *Theory Appl. Graphs*, **8(1)** Article 1, (2021), electronic.
- [5] D. Roberts and R.M. Low, Group-antimagic labelings of multi-cyclic graphs, *Theory Appl. Graphs*, **3(1)** Article 6, (2016), electronic.
- [6] A. Rosa, On certain valuations of the vertices of a graph, in: *Théorie des graphes, journées internationales d'études, Rome 1966* (Dunod, Paris, 1967) 349–355.
- [7] W.C. Shiu and R.M. Low, The integer-antimagic spectra of dumbbell graphs, *Bull. Inst. Combin. Appl.*, **77** (2016), 89–110.
- [8] W.C. Shiu and R.M. Low, Integer-antimagic spectra of complete bipartite graphs and complete bipartite graphs with a deleted edge, *Bull. Inst. Combin. Appl.*, **76** (2016), 54–68.
- [9] W.C. Shiu, P.K. Sun, and R.M. Low, Integer-antimagic spectra of tadpole and lollipop graphs, *Congr. Numer.*, **225** (2015), 5–22.